

Day/Night Camera

Super High Resolution Day/Night Camera

Features

- 1/3" SONY Super HAD CCD
- 550 TVL Resolution
- Auto Tracing White Balance
- Dual V12DC/V24AC Power



Specifications

Model	CV-C550D
Image Pick-up Device	SONY 1/3" Hi-Res. Super HAD CCD
Scanning System	2:1 Interlace
Effective Picture Elements	NTSC: 768*494, PAL: 752*582 (H*V)
Horizontal Resolution	550 TV lines
Lens Mount	C/CS Mount
Minimum Illumination	Day (0.3 Lux), Night (0.001 Lux)
S/N Ratio	More than 50dB (AGC Off)
Auto Electronic Shutter	X128~1/60s~1/120,000s, ON/OFF switch
Noise Reduction	Automatic
Auto Iris Control	Video & DC-Drive Lens supported
Gamma Characteristic	0.45
Auto Gain Control	AGC High / Low switchable.
Auto White Balance	ATW (Auto) switchable
Back Light Compensation	ON/OFF Switch-able
Synch System	Internal
Video Output	Composite: 1 Vp-p / 75 Ohms, Unbalanced
Power Supply	12VDC/24VAC
Power Consumption	4W
Operating Temp.	-10°C to 50°C (14°F to 122°F)

Dimensions

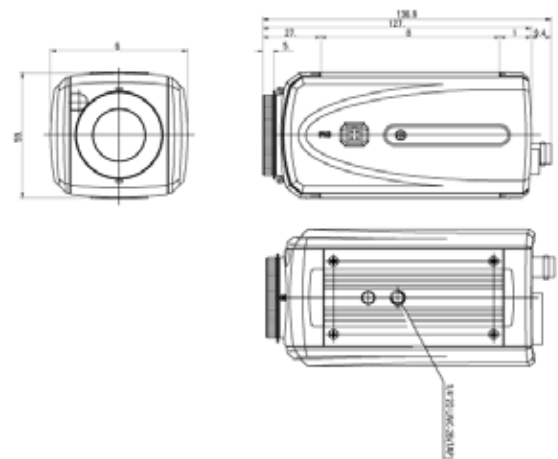

ClearVision and the ClearVision Logo are registered trademarks of ClearVision, Inc.
 Sony is a registered trademark of Sony Corporation
 Lens Not Included.
 Product specifications and availability are subject to change without notice.
 ©Copyright 2008, ClearVision, Inc. All rights reserved.