

Medium Resolution Box Camera

Box style cameras allow for the use of a variety of lenses, housings, and indoor/outdoor mounting options.

Features

- 1/3" SONY Super HAD CCD
- 50 TV Line Resolution
- Auto Tracing White Balance
- Low Power Consumption



* Lens Not Included

Specifications

Model	CV-C530
Signal System	NTSC
Scanning System	2:1 Interface
Scanning Frequency(H)	15.734 KHz
Scanning Frequency(V)	59.94 Hz
Image Sensor	1/3 " Super HAD CCD
Sync. System	Internal
Total Pixels Number	811(H) x 508(V) 410K
Effective Pixels Number	768(H) x 494(V) 380K
Horizontal Resolution	530 TV Lines
Video Output Level	1.0V p-p (75Ω, Composite)
S/N Ratio	More than 48dB (AGC Off)
Lens Mount	C/CS Mount
Min. Illumination	Day 0.3 Lux
White Balance	AUTO
AGC	On/Off
OSD Menu	On/Off
Privacy Zone	On/Off (4 Programmable Zone)
Motion detection	On/Off (64 Programmable Zone)
Electronic Shutter Speed	1/60 ~ 1/100,000sec
Power Voltage	DC9V
Power Consumption	Max. 3W
Dimensions	62(W) x 58(H) x 73.6(D) mm
Weight (Net)	Approx. 335g

Dimensions

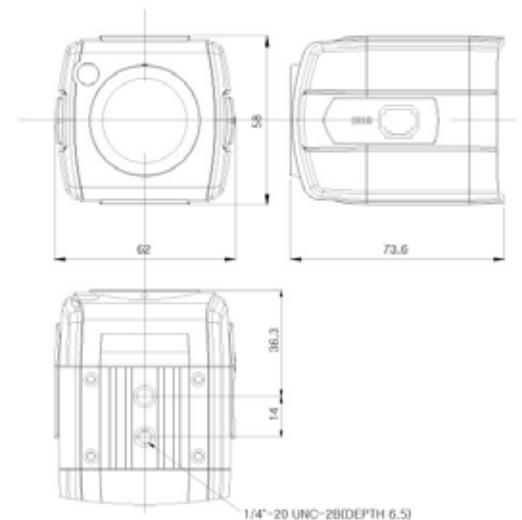

ClearVision and the ClearVision Logo are registered trademarks of ClearVision, Inc.
 Sony is a registered trademark of Sony Corporation
 Product specifications and availability are subject to change without notice.
 ©Copyright 2008, ClearVision, Inc. All rights reserved.