

Medium Resolution Box Camera

Box style cameras allow for the use of a variety of lenses, housings, and indoor/outdoor mounting options.

Features

- 1/3" SONY Super HAD CCD
- 380 TV Line Resolution
- Auto Tracing White Balance
- Low Power Consumption



* Lens Not Included

Specifications

Model	CV-C380
Scanning Frequency(H)	15.734 KHz
Scanning Frequency(V)	59.94 Hz
Sync System	Internal
Image Sensor	1/3 inch Sony Super HAD CCD
Lens Mount	C/CS Mount
Iris Mode	Video/DC
S/N Ratio	48dB
Resolution	Horizontal : 380 TV Lines
Video Output Level	1.0 Vp-p (75 Ohms, Composite)
Sensitivity	0.8 lx / F=1.2
Electronic Shutter	1/60 ~ 1/100,000 Sec
White Balance	On / Off
AGC	On / Off
BLC	On / Off
Supplied Voltage	24VAC / 12VDC
Power Consumption	150mA
Dimensions(WxHxD)	64 x 56 x 102 mm
Weight	Approx. 225g

Dimensions

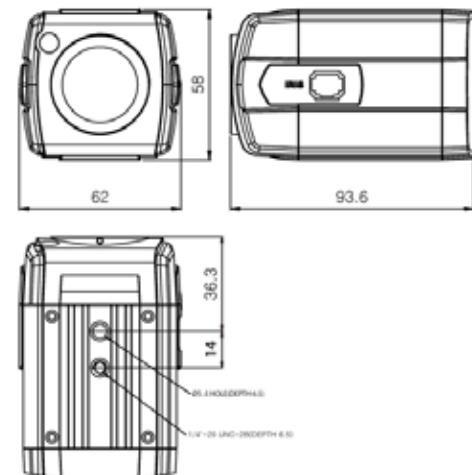

ClearVision and the ClearVision Logo are registered trademarks of ClearVision, Inc.
 Sony is a registered trademark of Sony Corporation
 Product specifications and availability are subject to change without notice.
 ©Copyright 2008, ClearVision, Inc. All rights reserved.