

Corner Mount Camera

Features

- 1/3" SONY Super HAD CCD
- 530 TVL Resolution
- Build-in Fixed Lens (f=3.8mm)
- Min. Illumination: 0.3 Lux
- Auto White Balance
- Vandal-Resistant Housing



Specifications

Model	CV-C530CM
Signal System	NTSC
Scanning System	2:1 interlace
Scanning Frequency(H)	5.734kHz
Scanning Frequency(V)	59.94Hz
Image Sensor	1/3" SONY Super HAD CCD
Sync. System	Internal
Total Pixels Number	811(H) x 508(V) 410K
Effective Pixels Number	768(H) x 494(V) 380K
Horizontal Resolution	530 TV lines
Video Output Level	1.0Vp-p (75Ω, composite)
Lens	Fixed lens
Min. Illumination	0.3 Lux
White Balance	Auto
Focus Mode	Manual
Electronic Shutter Speed	1/60~1/100,000sec
Dimensions	55(Ø) x 85(W) x 85(H)

Dimensions

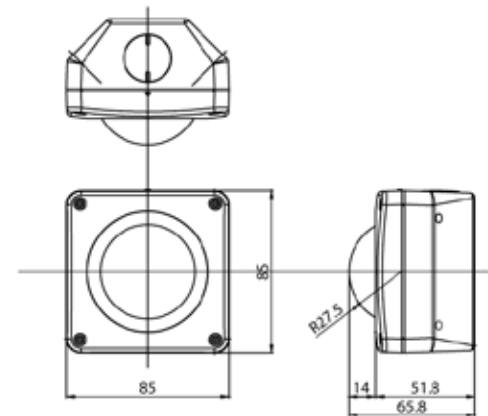

ClearVision and the ClearVision Logo are registered trademarks of ClearVision, Inc.
 Sony is a registered trademark of Sony Corporation
 Product specifications and availability are subject to change without notice.
 ©Copyright 2008, ClearVision, Inc. All rights reserved.